

Series 5000 Rotary stage

An accurate, heavy-duty range of rotary stages which allows precise rotary positioning of objects by stepping or servo motor control. A precision worm and wheel with a 90:1 gear ratio provides repeatable, zero-backlash positioning with high load capacity. A magnetic Datum switch is included. Stepping or servo motor control with a rear-mounted encoder ensures accurate indexing.

All connections are made through a secure QM 19 way connector. The Series 5000 rotary stages may be designed as azimuth/elevation controlled gimbal assemblies by MotionLink. A through-hole feature is standard on all Series 5000 rotary stages.

These rotary stages are mechanically compatible with the MotionLink range of linear positioning stages.



OPTIONAL FEATURES

- Mechanical Datum switch
- Limit switches
- Integral direct rotary encoder
- *High load capacity option, HD, 250 & 300mm diameter

SPECIFICATION

Table diameter	150	250	300
Runout	+/- 0.07mm		
Accuracy	2 arc minutes		
Concentricity	+/- 0.02mm		
Repeatability	20 arc seconds - unidirectional		
Gear ratio	90:1		
Load capacity kg			
Stage horizontal	20	95	95
Stage vertical	9	20	20
Weight kg	4	12.5	13
Materials	Aluminium alloy and stainless steel		
Finish	Anodised and dyed black		

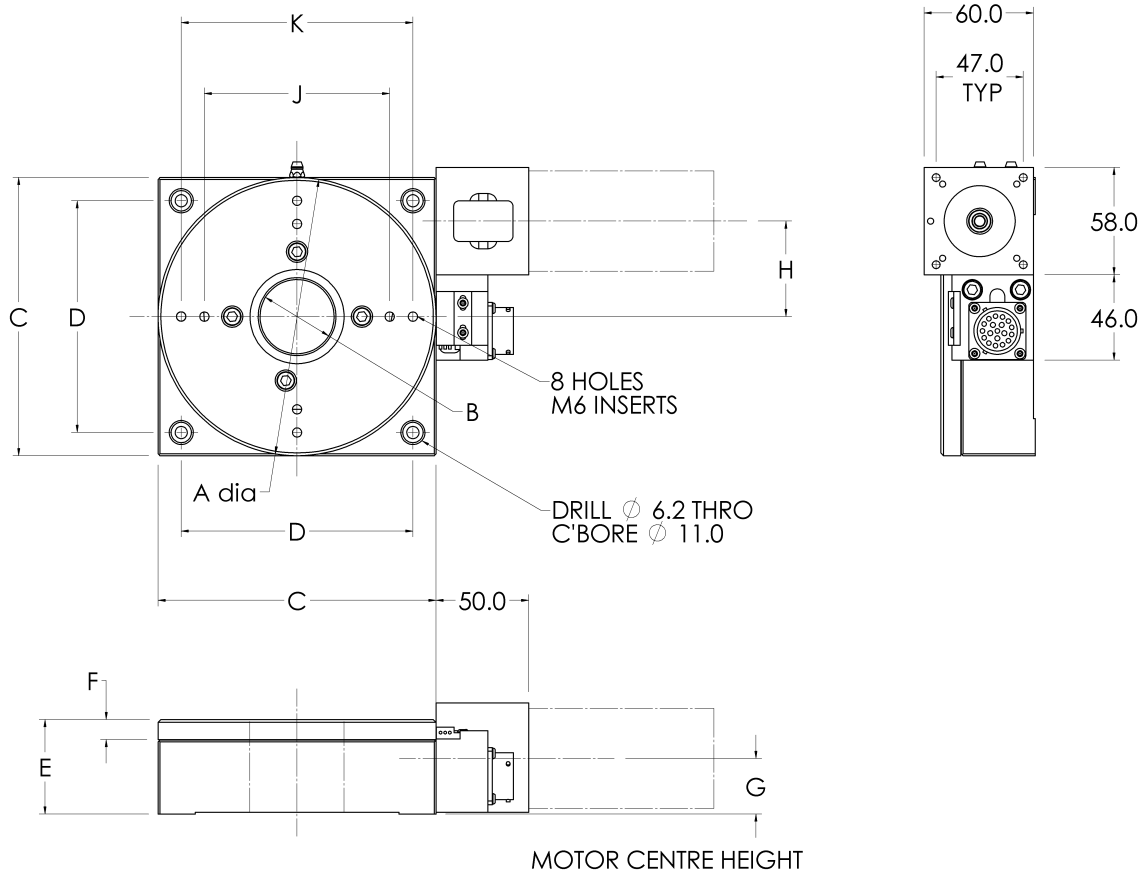

DIMENSIONS

Table Diameter mm	Dimensions mm									
	A	B	C	D	E	F	G	H	J	K
150	150	40 ^{H7}	150	125	51	10.85	29	59.5	100	125
250	250	70 ^{H7}	250	225	75	20	49	84	150	200
300	300	70 ^{H7}	250	225	75	20	49	84	200	250
*256HD	256	70 ^{H7}	256	225	90	20.3	49	84	150	200
*300HD	300	70 ^{H7}	256	225	90	20.3	49	84	200	250

For connections, see page 40